



# 承认书

## Approval Sheet

客户名称:

Customer

/

产品名称:

开放式绕线功率电感器

Part Name

Smd Power Inductor

产品规格:

Specification

JCD Series

版本号:

Version No.

A/0

日期:

Date

2020-7-3

制造Manufacturer			客户Customer		
拟制	审核	确认	检验	审核	批准
Draft by	Checked by	Approve by	Check by	Checked by	Approval by
周昶	杨岚	唐涛			



## 履 历 表 Resume

版本 Version No.	修 改 明 细 Modify Details	日期 Date
A/0	新制定	2020-7-3

序号No	目录 TABLE OF CONTENTS
1	产品指南Products Guide
2	特征Characteristics
3	应用Application
4	形状和尺寸Shape And Dimensions
5	规格Specifications
6	可靠性测试Reliability testing
7	产品包装 Packaging
8	使用注意事项Reminders For Using These Products

## 产品指南 Products Guide

Description	Model	P/N	Package Size	Inductance Range(uH)	DCR Max.(Ω)	IDC Max.(A)
Smd Power Inductors 绕线功率电感器		JCD	3516(CD31)	1-150	0.049-4.29	0.17-1.2
			3521(CD32)	1-820	0.048-23.4	0.06-2
			4521(CD42)	1-1500	0.033-20	0.08-3
			5830(CD53)	1-1000	0.017-2.08	0.17-3.7
			5845(CD54)	1-1000	0.02-6.89	0.17-5.4
			7835(CD73)	1-1000	0.01-4.5	0.08-6
			7850(CD75)	1-5000	0.013-20	0.08-5.2
			1054(CD105)	1-2200	0.008-5.68	0.17-8.45

### Characteristics 特征

- 铁氧体材料，开磁磁结构，价格低廉；
- 磁材上金属化电极，抗跌落冲击强，经久耐用；
- 电流特性较同等尺寸传统电感高30%；
- 节省空间，节省用电。

### Application 应用

- 智能手机，智能电视，机顶盒；
- 车载导航影音；
- 通讯设备；
- 虚拟现实设备；
- LED照明。

### 形状和尺寸 Shape And Dimensions (Unit: mm)

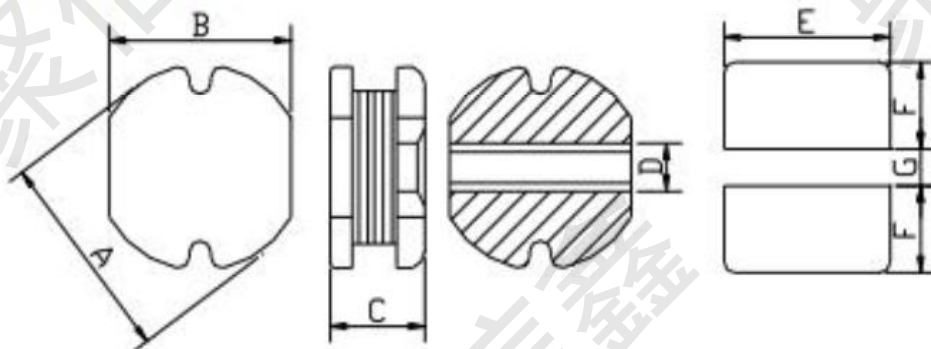

Size 型号	A	B	C	D	E (Ref.)	F (Ref.)	G (Ref.)
JCD3516(CD31)	3.5±0.3	3.0±0.3	1.6±0.3	1	3.2	1.3	1
JCD3521(CD32)	3.5±0.3	3.0±0.3	2.1±0.3	1	3.2	1.3	1
JCD4521(CD42)	4.5±0.3	4.0±0.3	2.1±0.3	1.2	4.5	1.8	1.5
JCD4532(CD43)	4.5±0.3	4.0±0.3	3.2±0.3	1.2	4.5	1.8	1.5
JCD5830(CD53)	5.8±0.3	5.2±0.3	3.0±0.3	1.3	5.5	2.2	1.7
JCD5845(CD54)	5.8±0.3	5.2±0.3	4.5±0.3	1.3	5.5	2.2	1.7
JCD7835(CD73)	7.8±0.3	7.0±0.3	3.5±0.3	2.1	7.5	3	2
JCD7850(CD75)	7.8±0.3	7.0±0.3	5.0±0.3	2.1	7.5	3	2
JCD1054(CD105)	10.0±0.3	9.0±0.3	5.4±0.3	2.1	9.5	3.75	2.5

**Product Spec. Model产品品名构成**

JCD      4532      D      101      M  
(1)      (2)      (3)      (4)      (5)

(1)Product symbol系列代号

(2)Dimensions外形尺寸

(3)Winding绕线方式 (D: Single Line单线, C: Double Line双线)

(4)Inductance电感量: 1R0:1.0μH 100:10μH 101:100μH;

(5)Tolerance公差: J/K/L/M/N 5% /10% /15% /20% /30%;

## Specifications规格

## JCD3516 Series

产品型号	L(uH)	测试频率(KHz/V)	电阻 Max.(Ω)	电流 Max.(A)
JCD3516D-1R0M	1	100/0.25	0.049	1.2
JCD3516D-1R8M	1.8	100/0.25	0.068	1.1
JCD3516D-2R2M	2.2	100/0.25	0.089	0.98
JCD3516D-3R3M	3.3	100/0.25	0.12	0.95
JCD3516D-4R7M	4.7	100/0.25	0.163	0.9
JCD3516D-5R6M	5.6	100/0.25	0.182	0.85
JCD3516D-6R8M	6.8	100/0.25	0.234	0.81
JCD3516D-8R2M	8.2	100/0.25	0.26	0.71
JCD3516D-100K	10	100/0.25	0.357	0.61
JCD3516D-120K	12	100/0.25	0.377	0.58
JCD3516D-150K	15	100/0.25	0.442	0.53
JCD3516D-180K	18	100/0.25	0.52	0.48
JCD3516D-220K	22	100/0.25	0.637	0.43
JCD3516D-270K	27	100/0.25	0.767	0.41
JCD3516D-330K	33	100/0.25	1.01	0.37
JCD3516D-390K	39	100/0.25	1.11	0.34
JCD3516D-470K	47	100/0.25	1.68	0.3
JCD3516D-820K	82	100/0.25	2.66	0.25
JCD3516D-101K	100	100/0.25	3.15	0.2
JCD3516D-151K	150	100/0.25	4.29	0.17

Note:

1、Tolerance: N:±30% , M:±20% , K:±10%;

2、IDC:DC current at which the inductance drops approximate 10% from its value without current;

### JCD4521 Series

产品型号	L(uH)	测试频率(KHz/V)	电阻 Max.(Ω)	电流 Max.(A)
JCD4521D-1R0M	1	100/0.25	0.03	2.5
JCD4521D-1R5M	1.5	100/0.25	0.04	1.8
JCD4521D-2R2M	2.2	100/0.25	0.05	1.6
JCD4521D-3R3M	3.3	100/0.25	0.06	1.5
JCD4521D-4R7M	4.7	100/0.25	0.1	1.3
JCD4521D-5R6M	5.6	100/0.25	0.08	1.1
JCD4521D-6R8M	6.8	100/0.25	0.1	1.05
JCD4521D-8R2M	8.2	100/0.25	0.11	1
JCD4521D-100K	10	100/0.25	0.17	0.92
JCD4521D-120K	12	100/0.25	0.18	0.82
JCD4521D-150K	15	100/0.25	0.2	0.8
JCD4521D-180K	18	100/0.25	0.25	0.73
JCD4521D-220K	22	100/0.25	0.427	0.7
JCD4521D-270K	27	100/0.25	0.477	0.62
JCD4521D-330K	33	100/0.25	0.525	0.6
JCD4521D-390K	39	100/0.25	0.654	0.56
JCD4521D-470K	47	100/0.25	0.668	0.54
JCD4521D-560K	56	100/0.25	0.73	0.52
JCD4521D-680K	68	100/0.25	1.36	0.5
JCD4521D-820K	82	100/0.25	1.45	0.48
JCD4521D-101K	100	100/0.25	1.5	0.45
JCD4521D-121K	120	100/0.25	1.53	0.35
JCD4521D-151K	150	100/0.25	2.4	0.34
JCD4521D-181K	180	100/0.25	2.86	0.32
JCD4521D-221K	220	100/0.25	4.1	0.25
JCD4521D-271K	270	100/0.25	5.14	0.24
JCD4521D-331K	330	100/0.25	7.15	0.21
JCD4521D-391K	390	100/0.25	7.43	0.2
JCD4521D-471K	470	100/0.25	8.19	0.18
JCD4521D-681K	680	100/0.25	10.92	0.13
JCD4521D-102K	1000	100/0.25	24.23	0.12
JCD4521D-152K	1500	100/0.25	25.56	0.09

Note:

- 1、Tolerance: N:±30% , M:±20% , K:±10%;
- 2、IDC:DC current at which the inductance drops approximate 10% from its value without current;

### JCD4532 Series

产品型号	L(uH)	测试频率(KHz/V)	电阻 Max.(Ω)	电流 Max.(A)
JCD4532D-1R0M	1	100/0.25	0.033	3
JCD4532D-1R5M	1.5	100/0.25	0.036	2.5
JCD4532D-2R2M	2.2	100/0.25	0.042	2.3
JCD4532D-3R3M	3.3	100/0.25	0.051	2.1
JCD4532D-3R9M	3.9	100/0.25	0.07	1.9
JCD4532D-4R7M	4.7	100/0.25	0.08	1.6
JCD4532D-5R6M	5.6	100/0.25	0.08	1.45
JCD4532D-6R8M	6.8	100/0.25	0.1	1.35
JCD4532D-8R2M	8.2	100/0.25	0.12	1.3
JCD4532D-100K	10	100/0.25	0.15	1
JCD4532D-120K	12	100/0.25	0.16	0.9
JCD4532D-150K	15	100/0.25	0.2	0.8
JCD4532D-180K	18	100/0.25	0.23	0.7
JCD4532D-220K	22	100/0.25	0.27	0.6
JCD4532D-270K	27	100/0.25	0.331	0.55
JCD4532D-330K	33	100/0.25	0.35	0.5
JCD4532D-390K	39	100/0.25	0.4	0.48
JCD4532D-470K	47	100/0.25	0.53	0.4
JCD4532D-560K	56	100/0.25	0.6	0.38
JCD4532D-680K	68	100/0.25	0.74	0.33
JCD4532D-820K	82	100/0.25	0.88	0.29
JCD4532D-101K	100	100/0.25	1.2	0.26
JCD4532D-121K	120	100/0.25	1.25	0.24
JCD4532D-151K	150	100/0.25	1.6	0.22
JCD4532D-181K	180	100/0.25	2	0.19
JCD4532D-221K	220	100/0.25	3.08	0.18
JCD4532D-271K	270	100/0.25	3.25	0.16
JCD4532D-331K	330	100/0.25	3.55	0.15
JCD4532D-391K	390	100/0.25	4.2	0.13
JCD4532D-471K	470	100/0.25	4.9	0.12
JCD4532D-561K	560	100/0.25	6.5	0.11
JCD4532D-681K	680	100/0.25	10	0.1
JCD4532D-102K	1000	100/0.25	13.2	0.09
JCD4532D-152K	1500	100/0.25	20	0.08

Note:

- 1、Tolerance: N:±30% , M:±20% , K:±10%;
- 2、IDC:DC current at which the inductance drops approximate 10% from its value without current;



### JCD5830 Series

产品型号	L(uH)	测试频率(KHz/V)	电阻 Max.(Ω)	电流 Max.(A)
JCD5830C-1R0M	1	100/0.25	0.017	3.7
JCD5830C-1R5M	1.5	100/0.25	0.02	3.5
JCD5830C-2R2M	2.2	100/0.25	0.026	2.85
JCD5830C-3R3M	3.3	100/0.25	0.04	2.4
JCD5830C-3R9M	3.9	100/0.25	0.046	2.25
JCD5830C-4R7M	4.7	100/0.25	0.052	1.9
JCD5830C-5R6M	5.6	100/0.25	0.058	1.88
JCD5830C-6R8M	6.8	100/0.25	0.071	1.87
JCD5830C-8R2M	8.2	100/0.25	0.081	1.82
JCD5830D-100K	10	100/0.25	0.094	1.78
JCD5830D-120K	12	100/0.25	0.126	1.6
JCD5830D-150K	15	100/0.25	0.145	1.58
JCD5830D-180K	18	100/0.25	0.16	1.3
JCD5830D-220K	22	100/0.25	0.192	1.29
JCD5830D-270K	27	100/0.25	0.242	1.1
JCD5830D-330K	33	100/0.25	0.325	0.95
JCD5830D-390K	39	100/0.25	0.369	0.92
JCD5830D-470K	47	100/0.25	0.436	0.82
JCD5830D-560K	56	100/0.25	0.553	0.8
JCD5830D-680K	68	100/0.25	0.628	0.76
JCD5830D-820K	82	100/0.25	0.785	0.67
JCD5830D-101K	100	100/0.25	0.848	0.62
JCD5830D-121K	120	100/0.25	1.03	0.6
JCD5830D-151K	150	100/0.25	1.44	0.48
JCD5830D-201K	200	100/0.25	1.95	0.4
JCD5830D-221K	220	100/0.25	2.08	0.37
JCD5830D-271K	270	100/0.25	2.46	0.33
JCD5830D-331K	330	100/0.25	3.71	0.3
JCD5830D-391K	390	100/0.25	4.24	0.26
JCD5830D-471K	470	100/0.25	4.42	0.24
JCD5830D-561K	560	100/0.25	4.68	0.22
JCD5830D-681K	680	100/0.25	6.42	0.21
JCD5830D-821K	820	100/0.25	7.36	0.18
JCD5830D-102K	1000	100/0.25	9.73	0.17

Note:

- 1、Tolerance: N:±30% , M:±20% , K:±10%;
- 2、IDC:DC current at which the inductance drops approximate 10% from its value without current;

### JCD5845 Series

产品型号	L(uH)	测试频率(KHz/V)	电阻 Max.(Ω)	电流 Max.(A)
JCD5845C-1R0N	1	100/0.25	0.02	5.4
JCD5845C-1R5M	1.5	100/0.25	0.023	4.7
JCD5845C-2R2M	2.2	100/0.25	0.03	3.9
JCD5845C-3R3M	3.3	100/0.25	0.032	3.7
JCD5845C-4R7M	4.7	100/0.25	0.042	3.1
JCD5845C-5R6M	5.6	100/0.25	0.045	2.8
JCD5845C-6R8M	6.8	100/0.25	0.056	2.4
JCD5845C-8R2M	8.2	100/0.25	0.062	2.1
JCD5845D-100K	10	100/0.25	0.075	1.44
JCD5845D-120K	12	100/0.25	0.096	1.4
JCD5845D-150K	15	100/0.25	0.105	1.3
JCD5845D-180K	18	100/0.25	0.117	1.23
JCD5845D-220K	22	100/0.25	0.153	1.1
JCD5845D-270K	27	100/0.25	0.169	0.97
JCD5845D-330K	33	100/0.25	0.208	0.88
JCD5845D-390K	39	100/0.25	0.215	0.8
JCD5845D-470K	47	100/0.25	0.355	0.72
JCD5845D-560K	56	100/0.25	0.377	0.68
JCD5845D-680K	68	100/0.25	0.39	0.61
JCD5845D-820K	82	100/0.25	0.416	0.58
JCD5845D-101K	100	100/0.25	0.611	0.52
JCD5845D-121K	120	100/0.25	0.754	0.48
JCD5845D-151K	150	100/0.25	0.845	0.4
JCD5845D-181K	180	100/0.25	1.04	0.38
JCD5845D-221K	220	100/0.25	1.45	0.35
JCD5845D-271K	270	100/0.25	1.51	0.32
JCD5845D-331K	330	100/0.25	1.76	0.28
JCD5845D-391K	390	100/0.25	2.08	0.26
JCD5845D-471K	470	100/0.25	2.99	0.24
JCD5845D-561K	560	100/0.25	3.12	0.22
JCD5845D-681K	680	100/0.25	3.9	0.2
JCD5845D-801K	800	100/0.25	5.2	0.19
JCD5845D-821K	820	100/0.25	5.2	0.19
JCD5845D-102K	1000	100/0.25	6.89	0.17

Note:

1、Tolerance: N:±30% , M:±20% , K:±10%;

2、IDC:DC current at which the inductance drops approximate 10% from its value without current;

### JCD7835 Series

产品型号	L(uH)	测试频率(KHz/V)	电阻 Max.(Ω)	电流 Max.(A)
JCD7835C-1R0M	1	100/0.25	0.01	6
JCD7835C-1R2M	1.2	100/0.25	0.013	5.6
JCD7835C-2R2M	2.2	100/0.25	0.018	5.2
JCD7835C-3R3M	3.3	100/0.25	0.025	4
JCD7835C-3R9M	3.9	100/0.25	0.029	3.7
JCD7835C-4R7M	4.7	100/0.25	0.035	3.5
JCD7835C-5R6M	5.6	100/0.25	0.04	3
JCD7835C-6R8M	6.8	100/0.25	0.05	2.5
JCD7835C-8R2M	8.2	100/0.25	0.059	2
JCD7835D-100K	10	100/0.25	0.064	1.44
JCD7835D-120K	12	100/0.25	0.073	1.33
JCD7835D-150K	15	100/0.25	0.09	1.24
JCD7835D-180K	18	100/0.25	0.11	1.12
JCD7835D-220K	22	100/0.25	0.13	1.07
JCD7835D-270K	27	100/0.25	0.15	0.94
JCD7835D-330K	33	100/0.25	0.17	0.85
JCD7835D-390K	39	100/0.25	0.22	0.74
JCD7835D-470K	47	100/0.25	0.25	0.68
JCD7835D-560K	56	100/0.25	0.28	0.64
JCD7835D-680K	68	100/0.25	0.33	0.59
JCD7835D-820K	82	100/0.25	0.41	0.54
JCD7835D-101K	100	100/0.25	0.48	0.51
JCD7835D-121K	120	100/0.25	0.54	0.49
JCD7835D-151K	150	100/0.25	0.75	0.4
JCD7835D-181K	180	100/0.25	1.02	0.36
JCD7835D-221K	220	100/0.25	1.2	0.31
JCD7835D-271K	270	100/0.25	1.31	0.29
JCD7835D-331K	330	100/0.25	1.5	0.28
JCD7835D-391K	390	100/0.25	1.85	0.25
JCD7835D-471K	470	100/0.25	2.2	0.22
JCD7835D-561K	560	100/0.25	2.6	0.2
JCD7835D-681K	680	100/0.25	3.2	0.13
JCD7835D-821K	820	100/0.25	3.9	0.11
JCD7835D-102K	1000	100/0.25	4.5	0.08

Note:

1、Tolerance: N:±30% , M:±20% , K:±10%;

2、IDC:DC current at which the inductance drops approximate 10% from its value without current;

### JCD7850 Series

产品型号	L(uH)	测试频率(KHz/V)	电阻 Max.(Ω)	电流 Max.(A)
JCD7850C-1R0N	1	100/0.25	0.013	5.2
JCD7850C-1R5M	1.5	100/0.25	0.014	5
JCD7850C-2R2M	2.2	100/0.25	0.015	4.8
JCD7850C-3R3M	3.3	100/0.25	0.02	4
JCD7850C-4R7M	4.7	100/0.25	0.026	3.8
JCD7850C-5R6M	5.6	100/0.25	0.027	3.1
JCD7850C-6R8M	6.8	100/0.25	0.033	2.8
JCD7850C-8R2M	8.2	100/0.25	0.039	2.52
JCD7850C-100K	10	100/0.25	0.042	2.31
JCD7850C-120K	12	100/0.25	0.049	2
JCD7850D-150K	15	100/0.25	0.072	1.81
JCD7850D-220K	22	100/0.25	0.091	1.5
JCD7850D-330K	33	100/0.25	0.12	1.2
JCD7850D-470K	47	100/0.25	0.176	1.05
JCD7850D-560K	56	100/0.25	0.208	0.93
JCD7850D-680K	68	100/0.25	0.238	0.83
JCD7850D-820K	82	100/0.25	0.273	0.78
JCD7850D-101K	100	100/0.25	0.325	0.73
JCD7850D-121K	120	100/0.25	0.39	0.65
JCD7850D-151K	150	100/0.25	0.52	0.58
JCD7850D-181K	180	100/0.25	0.598	0.51
JCD7850D-221K	220	100/0.25	0.793	0.48
JCD7850D-331K	330	100/0.25	1.13	0.39
JCD7850D-471K	470	100/0.25	1.68	0.33
JCD7850D-561K	560	100/0.25	1.9	0.3
JCD7850D-681K	680	100/0.25	2.47	0.27
JCD7850D-821K	820	100/0.25	2.96	0.25
JCD7850D-102K	1000	100/0.25	4.4	0.24
JCD7850D-122K	1200	100/0.25	4.77	0.22
JCD7850D-152K	1500	100/0.25	5.65	0.2
JCD7850D-202K	2000	100/0.25	7.3	0.16
JCD7850D-222K	2200	100/0.25	7.8	0.15
JCD7850D-332K	3300	100/0.25	13.4	0.13
JCD7850D-502K	5000	100/0.25	20	0.08

Note:

1、Tolerance: N:±30% , M:±20% , K:±10%;

2、IDC:DC current at which the inductance drops approximate 10% from its value without current;

### JCD1054 Series

产品型号	L(uH)	测试频率(KHz/V)	电阻 Max.(Ω)	电流 Max.(A)
JCD1054C-1R0M	1	100/0.25	0.008	8.45
JCD1054C-1R5M	1.5	100/0.25	0.014	6.8
JCD1054C-2R2M	2.2	100/0.25	0.017	6
JCD1054C-3R3M	3.3	100/0.25	0.02	5
JCD1054C-4R7M	4.7	100/0.25	0.022	4.6
JCD1054C-5R6M	5.6	100/0.25	0.024	4
JCD1054C-6R8M	6.8	100/0.25	0.026	3.6
JCD1054C-8R2M	8.2	100/0.25	0.031	3.2
JCD1054C-100K	10	100/0.25	0.034	2.58
JCD1054C-120K	12	100/0.25	0.04	2.44
JCD1054C-150K	15	100/0.25	0.046	2.26
JCD1054C-180K	18	100/0.25	0.058	2.13
JCD1054D-220K	22	100/0.25	0.07	1.93
JCD1054D-270K	27	100/0.25	0.084	1.74
JCD1054D-330K	33	100/0.25	0.092	1.46
JCD1054D-470K	47	100/0.25	0.144	1.26
JCD1054D-560K	56	100/0.25	0.159	1.15
JCD1054D-680K	68	100/0.25	0.2	1.1
JCD1054D-820K	82	100/0.25	0.23	0.98
JCD1054D-101K	100	100/0.25	0.26	0.95
JCD1054D-121K	120	100/0.25	0.351	0.87
JCD1054D-151K	150	100/0.25	0.403	0.74
JCD1054D-181K	180	100/0.25	0.494	0.7
JCD1054D-221K	220	100/0.25	0.572	0.65
JCD1054D-271K	270	100/0.25	0.728	0.54
JCD1054D-331K	330	100/0.25	0.845	0.5
JCD1054D-391K	390	100/0.25	1.04	0.46
JCD1054D-471K	470	100/0.25	1.18	0.45
JCD1054D-561K	560	100/0.25	1.42	0.4
JCD1054D-681K	680	100/0.25	1.99	0.28
JCD1054D-821K	820	100/0.25	2.03	0.24
JCD1054D-102K	1000	100/0.25	2.47	0.22
JCD1054D-152K	1500	100/0.25	4.36	0.2
JCD1054D-222K	2200	100/0.25	5.68	0.17

Note:

- 1、Tolerance: N:±30% , M:±20% , K:±10%;
- 2、IDC:DC current at which the inductance drops approximate 10% from its value without current;

### 可靠性测试 Reliability testing

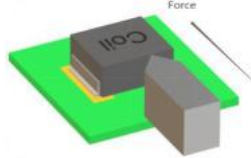
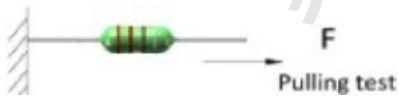
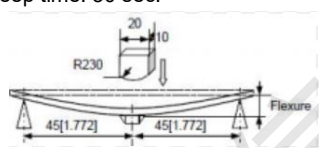
Items	Requirements	Test Methods and Remarks
Terminal Strength Reference documents: GB/T 2423.60-2008 端子强度(SMT)	<p>1. Pulling test: Define: A: sectional area of terminal <math>A \geq 8\text{mm}^2</math> force <math>\geq 5\text{N}</math> time: 30sec <math>8\text{mm}^2 &lt; A \leq 20\text{mm}^2</math> force <math>\geq 10\text{N}</math> time: 10sec <math>20\text{mm}^2 &lt; A</math> force <math>\geq 20\text{N}</math> time: 10sec</p> <p>2. Solder paste thickness: 0.12mm</p> <p>3. Meet the above requirements without any loose terminal</p>	<p>Solder the inductor to the testing jig using leadfree solder. Then apply a force in the direction shown</p> <p>Keep time: <math>10 \pm 1\text{s}</math> Speed: 1.0mm/s.</p> 
Terminal Strength Reference documents: GB/T 2423.60-2008 端子强度(DIP)	<p>1. Terminal diameter(d) mm <math>0.35 &lt; d \leq 0.50</math> Applied force: 5N Duration: 10sec</p> <p>2. Terminal diameter(d) mm <math>0.50 &lt; d \leq 0.80</math> Applied force: 10N Duration: 10sec</p> <p>3. Terminal diameter(d) mm <math>0.80 &lt; d \leq 1.25</math> Applied force: 20N Duration: 10sec</p> <p>4. Terminal diameter(d) mm <math>D &gt; 1.25</math> Applied force: 40N Duration: 10sec</p> <p>5. Meet the above requirements without any loose terminal.</p>	<p>Pull Force: the force shall be applied gradually to the terminal and then maintained for 10 seconds.</p> 
Resistance to Flexure JIS C 5321:1997 抗弯曲性试验	<p>1. No visible mechanical damage.</p>	<p>1. Solder the inductor to the test jig (glass epoxy board)</p> <p>2. shown in Using a leadfree solder. Then apply a force in the direction shown</p> <p>3. Flexure: 2mm.</p> <p>4. Pressurizing Speed: 0.5mm/sec.</p> <p>5. Keep time: 30 sec.</p> 
Dropping Reference documents: GB/T 2423.7-2018 落下试验	<p>1. No case deformation or change in appearance.</p> <p>2. No short and no open.</p>	<p>1. Drop the packaged products from 1m high in 1 angle, 3 ridges and 6 surfaces, twice in each direction.</p>
Solderability Reference documents: GB/T 2423.28-2005 可焊性试验	<p>1. No visible mechanical damage.</p> <p>2. Wetting shall exceed 75% coverage for</p> <p>3. Terminals must have 95% minimum solder coverage</p>	<p>1. Solder temperature: <math>240 \pm 2^\circ\text{C}</math></p> <p>2. Duration: 3 sec.</p> <p>3. Solder: Sn/3.0Ag/0.5Cu.</p> <p>4. Flux: 25% Resin and 75% ethanol in weight</p>

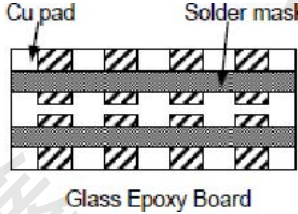
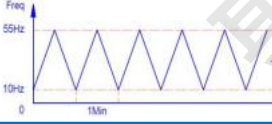
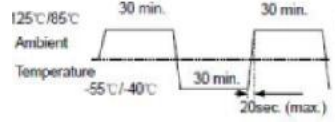
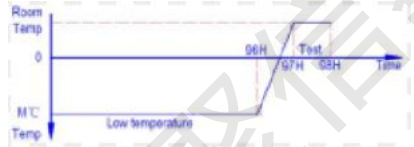
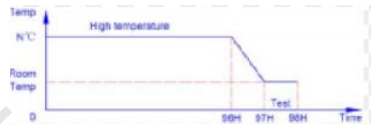
Items	Requirements	Test Methods and Remarks
Vibration Reference documents: GB/T 2423.10-2019 振动试验	1.No visible mechanical damage. 2. Inductance change: Within $\pm 10\%$ . 3.Q factor change: Within $\pm 20\%$ . 	1.Solder the inductor to the testing jig (glass epoxy boardshown in ) using leadfree solder. 2.The inductor shall be subjected to a simple harmonic motion having total amplitude of 1.5mm, the frequency being varieduniformly between the approximate limits of 10 and 55 Hz. 3.The frequency range from 10 to 55 Hz and return to 10 Hz shallbe traversed in approximately 1 minute. This motion shall be applied for a period of 2 hours in each 3mutually perpendicular directions(total of 6 hours). 
Thermal Shock Reference documents: GB/T 2423.22-2012 Method Na 冷热冲击试验	1.No visible mechanical damage. 2. Inductance change: Within $\pm 10\%$ .(Mn-Zn: Within $\leq 30\%$ ) 3.Q factor change: Within $\pm 20\%$ .	1.Start at ( 85~125℃ ) for T time, rush to (-55~40℃ ) for T time as one cycle, go through100 cycles. 2.Transforming interval: Max. 20 sec. 3.Tested cycle: 100 cycles. 4.The chip shall be stabilized at normal condition for 1~2 hours 
Low temperature Storage Reference documents: GB/T 2423.1-2008 Method Ab 低温储存试验	1.No visible mechanical damage. 2. Inductance change: Within $\pm 10\%$ .(Mn-Zn: Within $\leq 30\%$ ) 3.Q factor change: Within $\pm 20\%$ .	1.Temperature:M(-55~-40 $\pm 2^\circ\text{C}$ ) 2.Duration: 96 $\pm 2$ hours 3.The chip shall be stabilized at normal condition for 1~2 hoursbefore measuring. 
High temperature Storage Reference documents: GB/T 2423.2-2008 Method Bb 高温储存试验	1.No visible mechanical damage. 2. Inductance change: Within $\pm 10\%$ .(Mn-Zn: Within $\leq 30\%$ ) 3.Q factor change: Within $\pm 20\%$ .	1.Temperature:N(125~85 $\pm 2^\circ\text{C}$ ) 2.Duration: 96 $\pm 2$ hours 3.The chip shall be stabilized at normal condition for 1~2 hoursbefore measuring. 

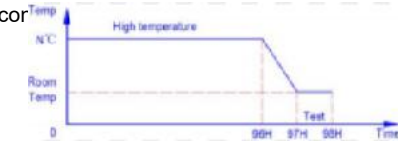
Items	Requirements	Test Methods and Remarks
Damp Heat (Steady States) Reference documents: GB/T 2423.3-2016 恒定湿热试验	1.No visible mechanical damage. 2. Inductance change: Within $\pm 10\%$ .(Mn-Zn: Within $\leq 30\%$ ) 3.Q factor change: Within $\pm 20\%$ .	1.Temperature: $60\pm 2^{\circ}\text{C}$ 2.Humidity: 90% to 95% RH. 3.Duration: $96\pm 2$ hours. 4.The chip shall be stabilized at normal cor 
Heat endurance of Reflow soldering Reference documents: GJB 360B-2009 回流焊耐热性试验	1.No significant defects in appearance. 2. $\Delta L/L \leq 10\%$ (Mn-Zn: $\Delta L/L \leq 30\%$ ) 3. $\Delta Q/Q \leq 30\%$ (SMD series only) 4. $\Delta DCR/DCR \leq 10\%$	1.Refer to the above reflow curve and go through the reflow for twice. 2.The peak temperature : $260+0/-5^{\circ}\text{C}$
Resistance to solvent test Reference documents: IEC 68-2-45:1993 耐溶剂性试验	No case deformation or change in appearance or obliteration of marking	To dip parts into IPA solvent for $5\pm 0.5$ Min,then drying them at room temp for 5Min,at last ,to brushing making 10 times.
Overload test Reference documents: JIS C5311-6.13 过负荷试验	1.During the test no smoke, no peculiar, smell, no fire 2.The characteristic is normal after test	Apply twice as rated current for 5 minutes.
voltage resistance test Reference documents: MIL-STD-202G Method 301 绝缘耐压测试	1.During the test no breakdown 2.The characteristic is normal after test	1. For parts with two coils 2. DC1000V, Current: 1mA, Time: 1Min. 3. Refer to catalogue of specific products



**推荐回流焊温度曲线 Recommended reflow soldering curve:**

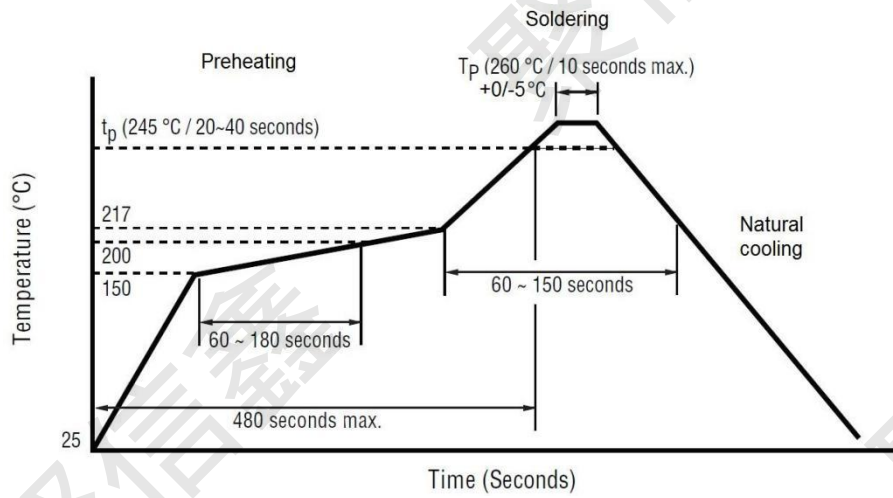

The recommended reflow conditions as above graph, is set according to our soldering equipment. DUE to various manufactures may have different reflow soldering equipment, products, process conditions, set methods. And so on, when setting the reflow conditions, Please adjust and confirm according to users' environment/equipment.

## 产品包装 Packaging

### Tape and Reel Specifications: (Dimensions are in mm)

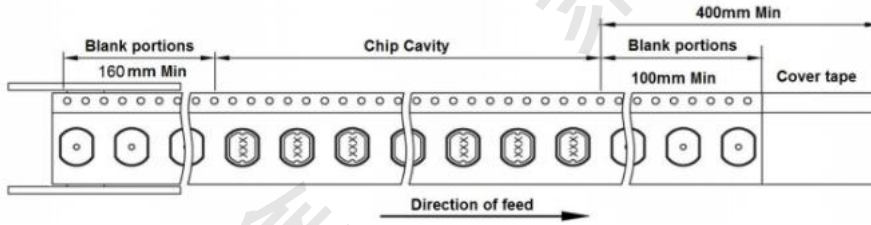

### Reel Dimensions (mm)

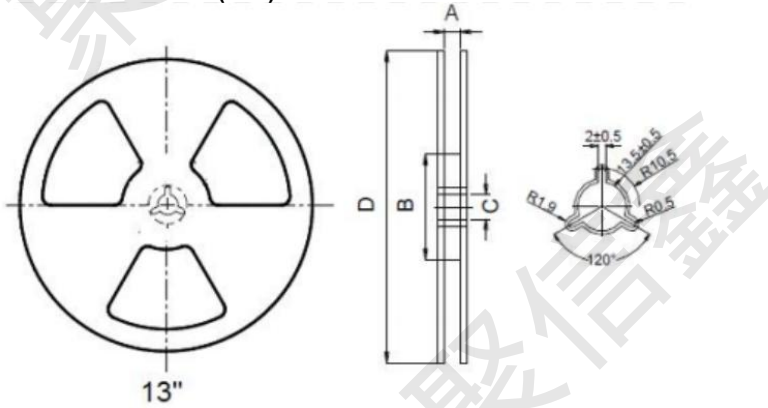

### Tape Dimension (mm)

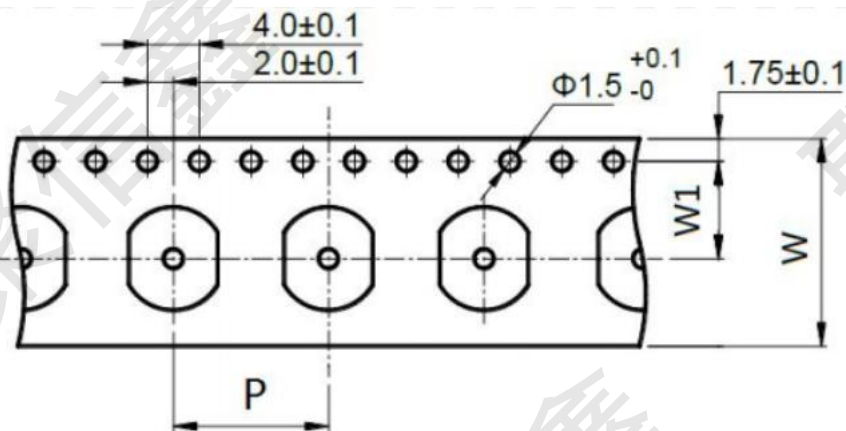

**Cover tape peel off condition**

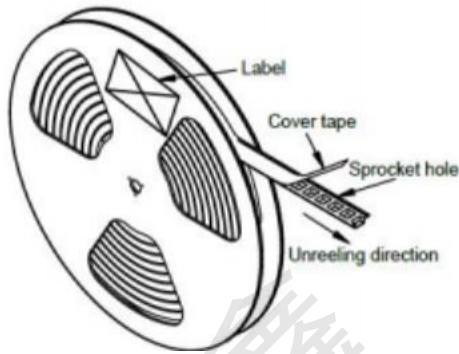

1) Cover tape peel force shall be 10 to 120g

2) Noodle strip peeling angle 165° to 180°

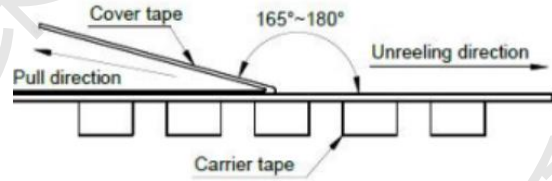

**Packing quantity**

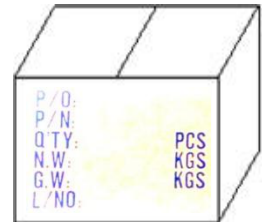
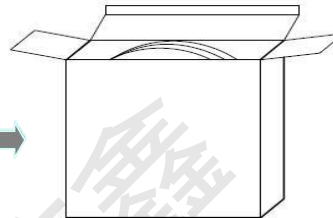
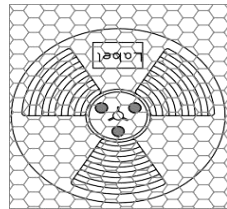

**Reel**

**PE袋**

**Inside Box**

**Outside Carton**

不足整箱用内盒或填充物装满

Part No.	Tape Dimension			Reel Dimensions				REEL (PCS)	Inside Box(PCS)	Outside Carton(PCS)
	W	P	W1	A	B	C	D			
JCD3516(CD31)	12	8	5.5	12.4	100	13	330	3000	12,000	48,000
JCD3521(CD32)	12	8	5.5	12.4	100	13	330	3000	12,000	48,000
4521(CD42)	12	8	5.5	12.4	100	13	330	2000	8,000	32,000
JCD5830(CD53)	16	8	7.5	16.4	100	13	330	2000	6,000	24,000
JCD5845(CD54)	16	8	7.5	16.4	100	13	330	1500	4,500	18,000
JCD7835(CD73)	16	12	7.5	16.4	100	13	330	1000	3,000	12,000
JCD7850(CD75)	16	12	7.5	16.4	100	13	330	1000	3,000	12,000
JCD1054(CD105)	24	12	11.5	24.4	100	13	330	1000	2,000	8,000

## 使用注意事项Reminders For Using These Products

●保存时间为12个月以内,保存条件(温度5~40°C以下、湿度35~66%RH以下),需充分注意。

若超过保存时间,端子电极的可焊性将可能老化。The storage period is within 12 months. Be sure to follow the storage conditions (temperature: 5~40°C, humidity: 35 to 65% RH or less). If the storage period elapses, the soldering of the terminal electrodes may deteriorate.

●请勿在气体腐蚀环境(盐、酸、碱等)下使用和保存。Do not use or store in locations where there are conditions such as gas corrosion (salt, acid, alkali, etc.).

●手上的油脂会导致可焊性降低,应避免用手直接接触端子。Don't touch electrodes directly with bare hands as oil secretions may inhibit soldering. Always ensure optimum conditions for soldering.

●请小心轻拿轻放,避免由于产品的跌落或取出不当而导致的损坏。Please always handle products carefully to prevent any damage caused by dropping down or inappropriate removing.

●端子过度弯曲会导致断线,请不要过度弯曲端子。Don't bend the terminals with excessive stress in case of any wire fracture.

●不要清洗产品,如需要清洗时请联系我司。Don't rinse coils by yourself and please contact JXX if necessary.

●请勿将本产品靠近磁铁或带有磁力的物体。Don't expose the products to magnets or magnetic fields.

●在实施焊接前,请务必进行预热。预热温度与焊接温度及芯片温度的温度差要在150°C以内。Before soldering, be sure to preheat components. The preheating temperature should be set so that the temperature difference between the solder temperature and chip temperature does not exceed 150°C.

●安装后的焊接修正应在规格书规定的条件范围内。若加热过度可能导致短路、性能降低、寿命减少。Soldering corrections after mounting should be within the range of the conditions determined in the specifications. If overheated, a short circuit, performance deterioration, or lifespan shortening may occur.

●装置会因通电而自我发热(温度上升),因此在热设计方面需留有充分余地。Self heating (temperature increase) occurs when the power is turned ON, so the tolerance should be sufficient for the set thermal design.

●非磁屏蔽型在基板设计时需注意配置线圈,受到电磁干扰可能会导致误动作。Carefully lay out the coil for the circuit board design of the non-magnetic shield type. A malfunction may occur due to magnetic interference.

●当本公司产品使用在一般电子设备以外的场合,如:车载,医疗设备,军用,航空航天等,请务必联系本公司营业部门,如超出本公司产品使用条件而引起的机器故障时,本公司概不负责。If JXX product will be applied in area like automotive product, medical equipment, military and aerospace except general electronic device, please keep JXX sales informed in advance. JXX shall not be held liable for any malfunction or breakdown caused by using product in the condition which is inconsistent with that recommended by JXX.